

MULTI-DIAMETER PIGGING – FACTORS AFFECTING THE DESIGN AND SELECTION OF PIGGING TOOLS FOR MULTI-DIAMETER PIPELINES

By Karl Dawson, Pipeline Engineering, Catterick Bridge, Richmond, UK

SUMMARY

Multi-Diameter Pigging – This paper will consider the process involved in pigging tool selection for pipelines with two or more significant internal diameters which require pigging tools capable of negotiating the different internal diameters whilst also carrying out the necessary pipeline cleaning operation.

The paper will include an analysis of pipeline features that affect pigging tool selection and then go on to look at other variables that determine the pigging tool design; this will include a step by step guide outlining how the tool is designed, the development of prototype pigs and the importance of testing and validation prior to final deployment in operational pigging programmes.

INTRODUCTION

For over 35 years Pipeline Engineering has provided pigging solutions for the oil and gas and related pipeline industries. Pipeline Engineering was a forerunner in the development of a reliable dual diameter pigging solution, and continues to advance this technology into multi diameter lines. With a track record of engineered design solutions to dual diameter and related pigging problems, the application of proven techniques together with new and innovative concepts has allowed the development of multi diameter pigs capable of negotiating multiple pipeline diameter changes and geometry conditions, together with specific launch and operational parameters.

Historically the need for a pipeline to be of single diameter construction with a constant bore, and bend radii of 5 times the internal diameter, was a requirement of pipeline inspection companies. This was to enable the clearance between their tools and the pipe wall to allow collection of the required data. If a pipeline followed this configuration it was deemed to be piggable.

The drive for cost effective design highlighted the potential savings in space, weight, fabrication and installation costs. It was found that if topside pipe work, risers and subsea manifolds were to be of a smaller diameter than the main pipeline, a considerable reduction in cost could be realised. The reduction in bore necessitated smaller valve configurations, branches and welded fittings such as tees and bends, which naturally led to reduced costs. The weight savings in these assemblies also reduced fabrication and installation outlay which also contributed to the overall reduction in cost.

The joining of lines within a field to a main transmission line to a central processing location provides a source of dual and multiple diameters. It is more cost efficient to tie into an available existing line than to lay a new line, with a benefit being shared maintenance and a reduced overall installation lead time. The size of a branch line can be smaller than the mainline, and is determined by the production output of the joining location.

The continuing development of deepwater fields has emphasised the requirement for economical design. The deeper water depths dictate higher pressure ratings and therefore thicker walled pipe systems, valves and fittings. With increasing field water depths come exponentially escalating construction costs, and as such any potential area for saving must be explored. With this, connectors, valves and features have been scrutinised with the result being that rather than reducing the overall diameter of the component, it is acceptable to reduce the internal diameter to achieve the thicknesses and cavities needed for form and

function. This then creates the opportunity for a vast quantity of internal diameters due to the array of manufacturers producing components to be included in assemblies.

A prime design consideration is that the line to be installed is piggable. This factor is generally never discounted when applying varying diameters, as flow assurance is a mandatory aspect to be addressed. A flow assurance program ensures line condition is maintained at a predetermined level, optimum flow conditions are achieved and product quality is retained. With the aforementioned taken into account, the drive for savings is still pressing and a direct approach can be achieved by pushing the boundaries of the term 'piggable'. A balance must therefore be struck between economy and functional viability.

THE PROCESS OF PIG SELECTION

Suitable pig selection is crucial to ensure that the desired task is carried out to the standard specified, within the project timescale and to the allocated budget. With this the drive for an engineered solution, which has been proven to be successful, the need for accurate information and provision of operating conditions is essential.

Foam and conical cup construction pigs can negotiate reductions in diameter, but are not specifically designed to cope with changes in diameter for considerable lengths of run. To fulfil the requirement of functioning within a dual or multi-diameter line, the pig is needed to be suitably designed to negotiate the predefined diameters, and to pass through the diameter specific features.

STEP BY STEP DESIGN GUIDE

To design a pig capable of negotiating a multi-diameter pipeline the parameters must firstly be clearly defined. Within the term parameter the following factors need to be considered:

- Internal Diameters
- Bend Radii
- Feature Definition and Configuration
- Lengths
- Transitions
- Location of Features
- Flow and Pressure Conditions
- Medium
- Expected Debris or Internal Line Condition
- Pig Trap
- Interaction of Pig Characteristics to Negotiate Features

INTERNAL DIAMETERS

The diameters present in a line need to be defined as accurately as possible, as all variations of the stated diameters can have an affect on the boundary conditions. The range of diameters needs to be broken down into a range for each core diameter. This could involve grouping schedules for each major diameter, or more likely similar sizes to allow a number of

defined ranges to be identified. The pig seal and support elements would then be sized to suit the ranges. If the ranges are found to be too great for the elements to accommodate, the ranges could be broken down further to necessitate additional elements for cover. The type of seal and support element and configuration will be selected based upon the range step changes, together with the length of run in each diameter and transitional conditions. The seal element could be a range of specially sized sealing discs (refer to Case Study), or an overlapping petal style disc (see Figure 1). The support element could be a modified traditional style support disc (see Case Study) or a hybrid Paddle Support (patent held by PE, see Figure 2). For larger diameters it may be necessary to employ a wheeled spring suspension arrangement to maintain alignment to the pipe centre line due to the increased weight of the pigging tool (Figure 3). The Figures below show the respective pig designs.



Figure 1 – Petal Type Pig

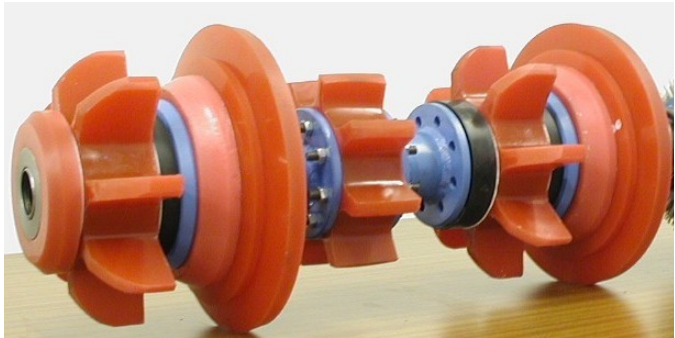

Figure 2 – Paddle Type Pig

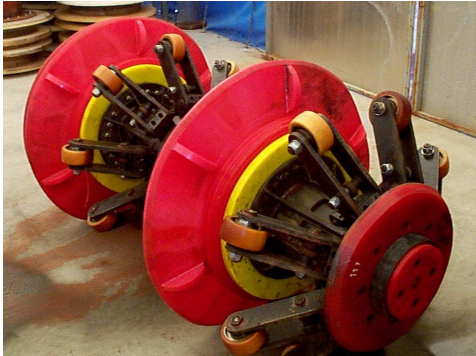

Figure 3 – Wheeled Suspension Pig

BEND RADII

The bend radii need to be defined together with the specific diameter in which the bend is formed. The portion of bend in angular terms and the method in which the bend is formed, such as induction bending or lobster back field fabrication, are also key factors for consideration. The pig length is of major consideration here, as a longer body is less likely to be able to traverse the bend, but a short pig would be unstable through straight length runs. The pig length is also influenced by the combination of features within the pipeline system.

FEATURE DEFINITION & CONFIGURATION

Definition of the feature and its particular configuration in the application require detailing. An example would be a tee, which could have a barred branch for pigging, or it may be a flow tee with through bore flow matched line pipe. The pig design needs to provide a positive seal across the feature to allow an efficient passage with no loss of drive which would lead to stalling. A wye piece is another example of branch which requires careful design consideration.

LENGTHS OF EACH SECTION

The length of each section in relation to diameter needs to be clearly defined to assist the review of the main diameters. This also provides a basis for selection of materials resistant to wear for the stated length.

TRANSITION BETWEEN DIAMETERS

The transitions between different diameters and features need to be investigated and simulated to ensure that they are not too abrupt, which could cause loss of a positive seal and therefore drive, and may also prevent the switch between the two sealing elements occurring as required in the transition between major diameters.

The length of run to each feature needs defining so that a map of the pig run can be built up for analysis purposes to enable the optimum pig design to be generated. The distance to each feature and the order in which they occur in the line are key pieces of information, of which a suitable design cannot be produced without.

FLOW & PRESSURE CONDITIONS

The stipulated flow and pressure conditions need to be taken into account and recommendations are to be made to ensure pig speeds are kept at the optimum level to prevent unnecessary wear and damage, but also to ensure an optimum cleaning speed as required. Bypass can be introduced to maintain flow but reduce pig speed, whilst introducing an efficient cleaning mechanism.

MEDIUM & ENVIRONMENT

The medium and environment in which the pig is to transit can be corrosive, and as such the materials and design are therefore suited to be resistant for successful receipt. A medium which is not self-lubricating, such as a dry gas line, can present a particular challenge as the seal and support elements can wear at a faster rate than in a lubricated line. Careful material selection of the affected elements ensures a suitable pig is designed for the task.

EXPECTED DEBRIS & INTERNAL LINE CONDITION

Depending upon the internal condition of a line and the medium transmitted, varying types and quantities of debris can be present. The array of types and quantities of debris dictate a specific approach, for example a bypass pig to allow through flow to suspend black powder in front of the pig to prevent a blockage and overloading of the pig receiver facilities.

PIG LAUNCHER & RECEIVER

The onsite launching and receiving facilities can restrict the overall length of the pig, and hence prevent the pig being designed to best suit the line geometry any feature combinations. An example of this is an ITAG pigging valve, which has a strict maximum length to allow a pig to be inserted and rotated into the main flow of the line to be launched.

INTERACTION OF LINE FEATURES

The interaction of individual line features may not at first appear to have a large bearing on pig design, but this could never be sufficiently stressed as an underestimated design premise. It is the interaction of pig characteristics designed to negotiate and traverse separate line features, which can potentially have an impact on passage through a feature which they are not required to be active in. An example of this is when a pig is designed to seal across a wye piece, the body is considerably longer than that of a standard pig. The pig could also be required to traverse a bend, but due to the revised length the pig may not be able to do this as the increase in length could have lowered its position in the bend causing a clash between the inside of the bend and the body material. Figure 4 shows the layout of such a scenario.

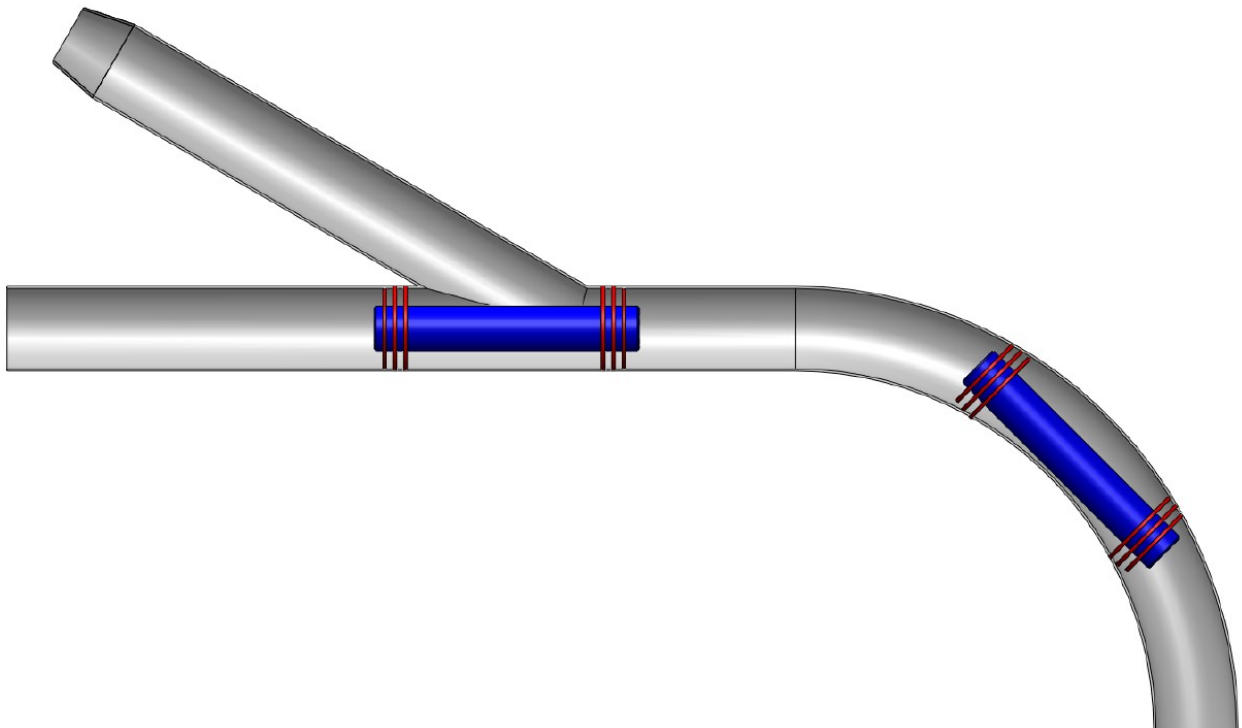

Figure 4 – Layout of Pig in Wye and Bend

The severity of the clash would be dependent upon the radius of the bend and may result in a loss of seal rather than a clash, this may be able to be rectified with a modification to the disc pack configuration. If the disc pack cannot be modified, the tool could be split into two modules with an articulated joint between the two pig bodies, this would allow passage around the bend and sealing across the wye.

PIPELINE DATA IS CRITICAL

The provision of line diametrical information and feature details are fundamental inputs into the design process. As previously stated, to achieve an optimum design all available line data is required, and where information is found missing measurements need to be taken where viable, for the full picture to be obtained. If the aforementioned is not obtained, the process of design will be extremely difficult to complete and depending upon the missing information may not be possible to complete. The objective is to provide a pig to suit the application and as such must be kept in mind when engineering a suitable solution, therefore assumptions and estimations must not take the place of fact, if information is found lacking a halt must be called to the design process until the information can be provided.

PROTOTYPE DEVELOPMENT AND THE IMPORTANCE OF TESTING AND VALIDATION

When a design has been developed to suit a particular application, it is trialled using CAD modelling through the diameters and features to be negotiated. The design basis and previous trial data are utilised to refine the design to achieve the most suitable solution. The true test and therefore validation of the design is to manufacture a prototype of the design solution and test the pig in a purpose made test rig. The test rig is to be designed to simulate the worst case scenario features and diameters which the pig will be subjected to when running through the field line. When testing the conditions under which the pig will operate in the field, such as flow and pressure, are simulated to ensure the test is as true a representation of the operational conditions as possible. This will therefore validate the pig for use in its intended application in the field. Data collected from testing can be used as a benchmark for flow and pressure readings in the simulated features, these can be compared to operational data to review performance.

It must be noted that testing is generally under ideal conditions with no pipe wall deposits such as wax, and no corrosion. It is however possible to apply such build ups and replicate corrosion pits and scours, to enable a true assessment of pig performance.

When testing it may be necessary to amend disc diameters and disc pack configurations to allow a smoother, more efficient passage through the features. A particular parameter to be noted when developing a dual or multi-diameter pig is bypass, modifications where possible are made to keep this to a minimum. Bypass can be reduced when the pig is traversing a straight pipe section and also in a bend, but it is at the transition to a larger diameter where it can only be reduced as the sealing elements respond to the variations and effect a positive seal.

Together with the validation of pig performance testing is an activity imperative to validate the functionality of a new or special pig design. Gaining data which can be used for operational purposes is a useful exercise, but testing the pig through the simulated field geometry and conditions is invaluable, as should a design feature not perform as intended, or an unexpected clash between the body and pipe wall occur and the pig become stuck, it can easily be removed from the test rig and the design rectified. The number of modifications and retests are unlimited, but when the operation requiring the pig takes place, only a single opportunity exists for success. The cost of recovering a stuck pig from a subsea manifold would be substantial and would undoubtedly delay a project with certain further financial impacts. With this the cost incurred in performing test loop trials are minimal in comparison, and could prevent a series of events detrimental to the success of a project.

CASE STUDY 8" X 10" PIPELINE OFFSHORE INDIA

Pipeline Engineering was approached to supply a pigging solution to negotiate 8" to 10" major diameters for commissioning activities and production pigging. For dewatering on the line the pig was to be propelled with Nitrogen to remove the water. The pig was to be back loaded into an 8" vertical subsea launcher which was then to be connected to a pipeline end termination through a reduced bore mechanical connector and into a 90° 5D bend. The pig was to perform a mandrel body roll flip and pass through the connector and 5D bend, then pass into a 10" line pipe section in which it was to travel 3.2 Km before negotiating a reduction in to 8" pipe, a 90° 5D bend, and a reduced bore connector before being received at the subsea manifold.

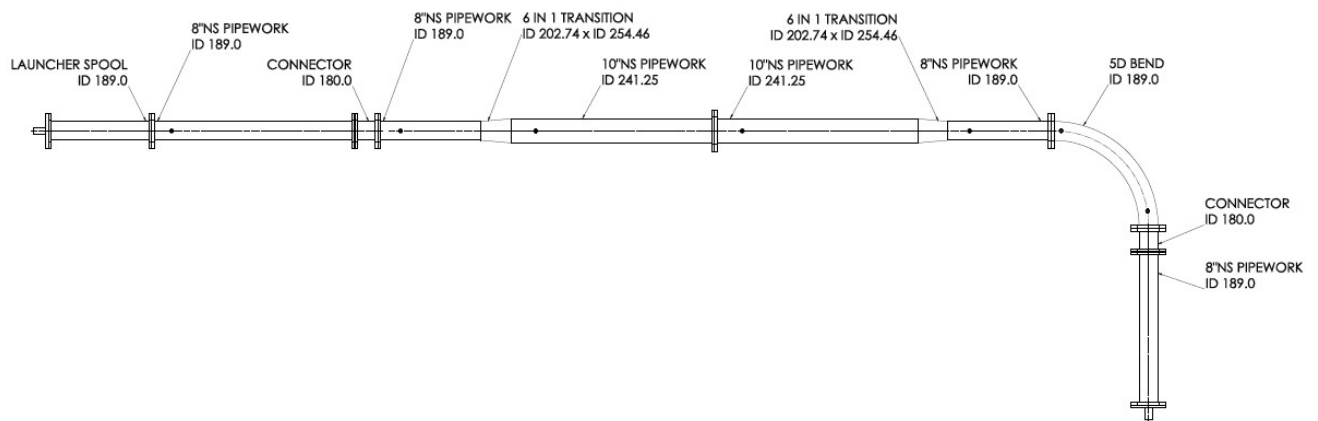

Figure 5 – Test Rig Layout

PIG OPERATIONAL REQUIREMENT

The operations were to be carried out subsea with both launch and receipt at 600m water depth. The pig was extensively tested and developed to ensure functionality was maintained under the parameters. The pig was required to negotiate the following:

8" Launcher and pipe work ID = 190.5 mm

Connector ID = 179.8 mm

5D bend ID = 190.5 mm

10" line ID = 241.3 mm

Tapered 1 in 6 transition

Length fixed at 400 mm due to laydown head design

PIG FUNCTIONAL REQUIREMENTS

1. Remove construction debris
2. Flood line for hydrotest
3. Dewater line

PIG DESIGN DEVELOPMENT AND VALIDATION TESTING

The pig design could not incorporate a suspension system, or a Paddle support system due to the bi-directional and back loading requirements, and the restriction on length. A segmented support system was employed for pliability through the reduced diameter connector, and to provide support in both the minor and major diameters. Dual seals were utilised for the 10" section, and single seals for the 8".

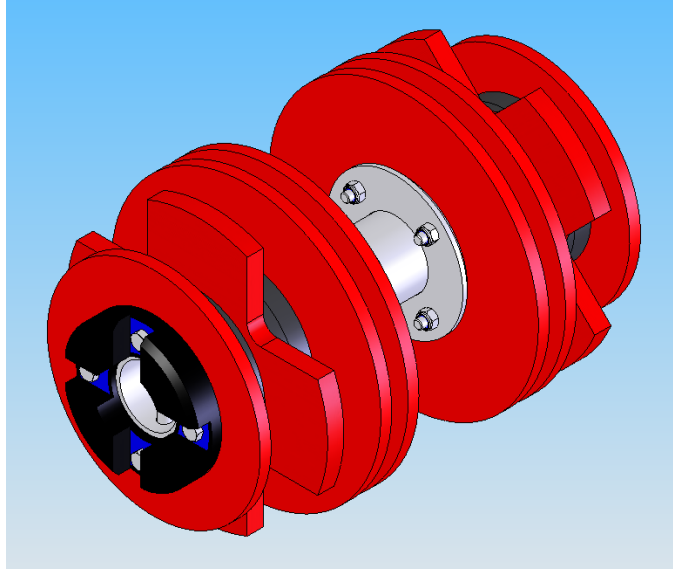

Figure 6 – 8" x 10" Pig Initial Design

When the trials commenced the design was found to be unsuccessful at negotiating the features, due to the reduced bore connector damaging the disc packs, preventing formation of an effective seal in the 10" pipe work. It was found that the annular clearance in the 8" pipe work was too small to allow for the 10" seal discs, and the required proportion of the support discs, to compress into.

The pig was subsequently re-designed and the prototype modified for further trials. A combination of radially grooved supports, arranged in a petal formation, was applied to support the pig in both diameters. Two 10" seal discs were removed and the disc pack spacing and body flange positions were revised for compression in the 8" pipe work.



Figure 7 – 8" x 10" Pig Successful Final Design

The pig was run through the test rig to fine tune the disc diameters, with the end result being that the pig was found to be successful.

The 8" x 10" pig will be used to flood and dewater lines in the field. It was therefore a requirement to test the pig using gas as a pigging medium to dewater the test rig. The main criterion for the dewatering test was that the pig can be received into the 8" pipe section with gas as the pigging medium. This test was carried out and design was again found to be successful.

TESTING RESULTS

As stated in the previous section the final pig design was found to be successful in the trials and was therefore validated as fit for purpose.

The following information details the differential pressures in each feature for water to water pigging:

Flip launch = 8.0 Bar

8" Pipe work = 7.5 Bar

Connector = 15.6 Bar

5D 90° Bend = 13.6 Bar

10" Pipe work = 0.9 Bar

Pass through reducer = 17.4 Bar

The differential pressures were quite high in the 8" diameter pipe work due to the compression of the 10" elements, with the main length of run having a differential as would be expected in this diameter.

The above results were mirrored with the air water test exercises.

The pig design was successfully launched and received in a number of field operations, and performed as required during these operations.

PAPER SUMMARY

The process of pig design can be eased by the interaction between client and vendor where a free flow of information is present. It is only under these circumstances where a true appreciation of the impact of line geometry upon the final pig design and operational capabilities can be gained. When developing a pigging tool suitable for a specific task it is essential that knowledge of the operations to be carried out is held by both parties.

Dual and multi-diameter pigs have long been proven to be successful during validation testing and field usage. Each design diameter difference has to be approached and appraised on a case by case basis, with individual minor changes being considered together with the overall major change. The interaction of the changes with the features must also be considered for a suitable design solution to be engineered.

With the cost of pipeline recovery and deepwater operations, validation testing is a necessary step to ensure a successful design solution has been supplied, and the risk to the project has been reduced to as low as reasonably practicable.